



limp
25 kA

Type 1 AC power Surge Protector DS250VG



The DS250VG is a Extreme Duty Type 1 AC Surge Protector Device (SPD) designed to be connected at the entrance of the electrical installation. This SPD provides an efficient protection against direct and indirect effects and is particularly useful in a high lightning density area where the risk of heavy surge current or even direct strike is high (e.g. : buildings equipped with lightning rods).

The DS250VG is a one-pole SPD and can be used in common mode (2, 3 or 4 DS250VGs connected between L/PE and N/PE = CT1 configuration) or common and differential mode (DS250VGs connected between L/N and 1 x DS100G between N/PE = CT2 configuration). See pages A20 and A21.

This SPD is designed to withstand a 25 kA lightning current (10/350 μ s impulse). It is based on specific heavy duty GDT and high energy MOV block : this technology allows the best behaviour possible on the AC network (no follow current and no leakage current) and a very low residual voltage.

The SPD is DIN rail compatible and is featured with a double terminal for line wire to allow improved connection to the AC network. To meet standards, the DS250VG includes a thermal disconnection mechanism, fault indicator and an internal microswitch for remote signaling.

- Type 1 Surge protector
- 25 kA on 10/350 μ s impulse**
- Low voltage Up
- Internal disconnection, status indicator and remote signaling
- IEC 61643-1 and EN 61643-11 compliance
UL 1449 ed. 2 recognition

Dimensions and Diagram

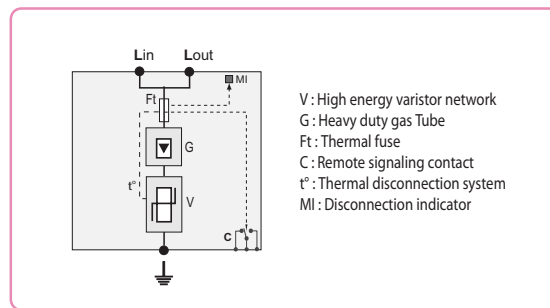
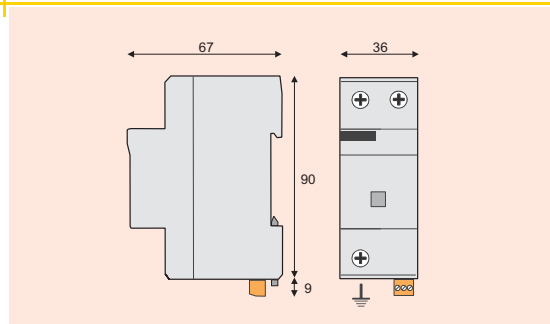

V : High energy varistor network
 G : Heavy duty gas Tube
 Ft : Thermal fuse
 C : Remote signaling contact
 t° : Thermal disconnection system
 MI : Disconnection indicator

Characteristics

CITEL part number	DS250VG-300	DS250VG-120
AC Network	230/400V	120/208V
Connection mode	L/N, L/PE	L/N, L/PE
AC system	TT, TN	TT, TN
Max operating voltage	Uc 255 Vac	150 Vac
TOV withstand	U 400 vac	150 Vac
Operating current	Ic none	none
Leakage current at Uc		
Follow current	If none	none
Nominal discharge current	In 30kA	30 kA
1.5 x 8/20 μ s impulses		
Maximal discharge current	I _{max} 70 kA	70 kA
max. withstand @ 8/20 μ s		
Max. lightning current by pole	limp 25 kA	25 kA
max. withstand @ 10/350 μ s		
Residual voltage (at limp)	Ures 0.8 kV	0.5 kV
Protection level (at In)	Up 1.5 kV	1 kV
Admissible short-circuit current	25000 A	25000 A
Associated disconnection devices		
Thermal disconnector	internal	
Fuses	Fuse type gG - 125 A max. (see Note 1)	
Installation ground fault breaker	Type «S» or delayed	
Mechanical characteristics		
Dimensions	see diagram	
Connection	by screw terminals : 6-35 mm ² / by bus	
Disconnection indicator	1 mechanical indicator	
Remote signaling of disconnection	output on changeover contact	
Mounting	symmetrical rail 35 mm	
Operating temperature	-40/+85 °C	
Protection class	IP20	
Housing material	Thermoplastic PEI UL94-5VA	
Standards compliance		
IEC 61643-1	International	Low Voltage SPD - Test Class I and II
EN 61643-11	Europe	Low Voltage SPD - Test Class I and II
NF EN 61643-11	France	Parafoudre Basse Tension - Essais Classe I et II
UL1449 ed.2	USA	Low Voltage TVSS

Note 1 : Rating in compliance with nominal discharge current. In order to increase service continuity, higher rating can be used (up to 250 A). For further information, please consult product instructions.